

# Technical Data Blow Molding Machine

**KCC15D**

## Dimensions and Space Requirements

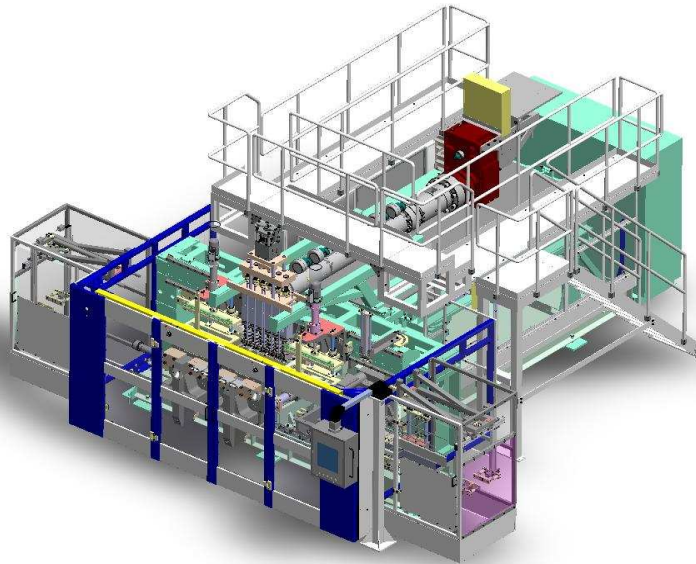

Length	app. mm	6.800	Width	app. mm	5.900	Height	app. mm	4.300
--------	---------	-------	-------	---------	-------	--------	---------	-------

These dimensions and space requirements only serve as a reference. For your detailed planning please ask for binding dimensional sketches

## Production Possibilities

Article dimensions			Parison Die Head	
Article diameter/Article thickness	max. mm	260	Center distance	Die diameter *
Article width	max. mm	480	max.	max.
Article length	max. mm	400	mm	mm
		1-fold		200
		2-fold	275	150
		3-fold	180	100
		4-fold	135	60
		5-fold	110	50
		6-fold	90	35
		7-fold	75	30
		8-fold	65	25
		9-fold	55	25

\* valid for monolayer application

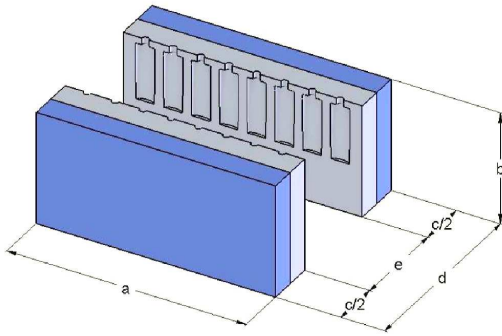

<b>Mold</b>			
Width	<b>a</b>	max. mm	610
Length	<b>b</b>	max. mm	500
Thickness	<b>c</b>	min. mm	2x 150
Mold weight		max. kg	2x 250
Carriage stroke		mm	620
Daylight between platens	<b>d</b>	min. mm	300
		max. mm	560
Clamp stroke	<b>e</b>	max. mm	260

Length incl. 50 mm superstructure

<b>Blow Molding Machine</b>		
Clamping force	kN	160
Closing speed	mm/s	700
Dry cycle time *	s	2,8
Work cycles max. **	1/h	790
Drive power hydraulic	kW	30

<b>Approximate Values for Energy Consumption</b>		
Air consumption - according to article volume and throughput		
Air pressure (required net pressure)	bar	8 - 10
Cooling performance for hydraulic (water inlet temperature max. 30°C)	max. kJ/h	46.500
Cooling performance for blow mold and extruder feed zone HDPE/HMWPE	$\frac{\text{kJ/h}}{\text{kg/h}}$	850

<b>Extruder</b>		<b>E70/25</b>	<b>E80/25</b>	<b>E90/25</b>	<b>E100/25</b>
Screw diameter	mm	70	80	90	100
Effective screw length	L/D	25	25	25	25
Heating capacity extruder [240V]	max. kW	17	20	24	24
Drive power	kW	45	55	75	90
Plasticizing capacity ***	HDPE kg/h	130	165	220	300
	PP kg/h	90	120	160	225

\* Sum of the movements, independent of the process

\*\* Referring to max. opening stroke without additional consumers (e.g. PWDS)

\*\*\* At a rate of 70 % virgin and 30 % regrind material

All descriptions, pictures, data and dimensions are not binding upon us. Shunde Kautex Plastics Technology Co Ltd. reserves the right to change designs and specifications without notice

**Kautex Maschinenbau GmbH**  
 Kautexstraße 54  
 D-53229 Bonn  
 Germany  
 Tel.: +49 (228) 489-0  
 Fax: +49 (228) 489-414

**Kautex Machines Inc.**  
 201 Chambers Brook Road  
 North Branch, NJ 08876  
 USA  
 Tel: +1 908 252 9350  
 Fax: +1 908 253 9565

**Kautex Maschinenbau GmbH**  
 Shanghai Office, Shanghai Universal Mansion  
 Room 2208, No. 168-172 Yu Yuan Road  
 Shanghai 200040; PRC  
 Tel: +86 21 6249 5806  
 Fax: +86 21 6249 1563